

ENG.NO. W0028-1409090

| | | | |
|--------|--------------------|------------|-----------|
| Rev 版次 | Revision note 變更內容 | Date 日期 | DR 制圖 |
| A0 | Original Release | Aug.27,09' | Kenny_shi |

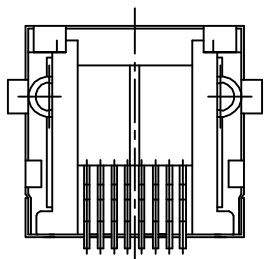
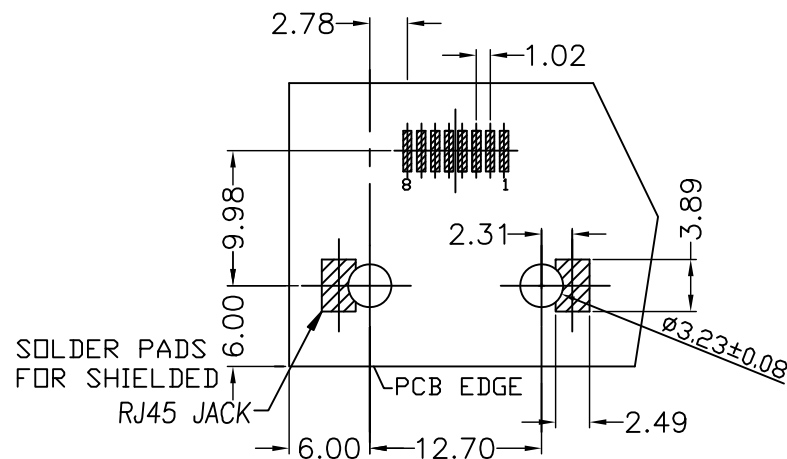
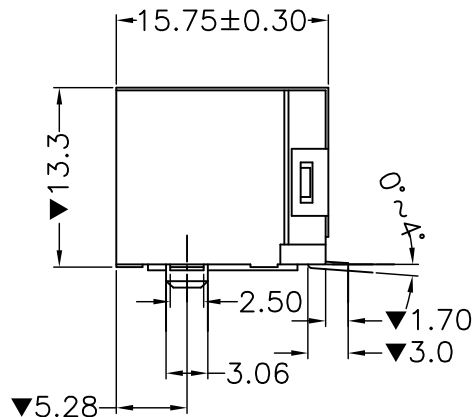
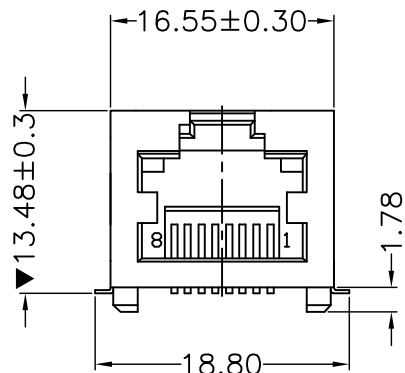

Ordering information:

3250S- 88XX000X2

RJ CONTACT PLATING CODE

- 02 : GOLD FLASH ON CONTACT AREA
- 03 : 3u" MIN GOLD ON CONTACT AREA
- 06 : 06u" MIN. GOLD ON CONTACT AREA
- 10 : 10u" MIN. GOLD ON CONTACT AREA
- 15 : 15u" MIN. GOLD ON CONTACT AREA
- 30 : 30u" MIN. GOLD ON CONTACT AREA
- 50 : 50u" MIN. GOLD ON CONTACT AREA

HOUSING COLOR

- Y:YELLOW
- B:BLACK
- G:GREEN

RECOMMENDED PCB LAYOUT (COMPONENT SIDE)

ELECTRICAL SPECIFICATION:

1. Rated Voltage And Current: Ac 125v Max, 1.5A Per Contact.
2. Insulation Resistance: 500 MΩ. Min.
3. Contact Resistance: 30mΩ Max.
4. Dielectric Withstanding Voltage: 500V/AC.
5. Operating Temperature: -40°C~+85°C.
6. "▼" Is Important Control Size.

RoHS COMPLIANT

| ITEM | DESC | Q'TY |
|------|--|------|
| ② | CONTACT :PHOSPHOR BRONZE GOLD/TIN PLATED | 8 |
| ① | HOUSING:GLASS FILLED POLYESTER UL94V-0 | 1 |

| | | | | | | |
|---|---|-----------------------|---|---------|---------|-----------|
| <p>威納電子 WINPOINT ELECTRONIC CORP. www.winpoint.com.tw</p> | <p>Title 名稱 RJ45 CONNECTOR DIP+SMT TYPE</p> | | | | | |
| | DR: 制圖 Xuzhihua | CHK'D 審核 Kenny_shi | APP'D 核准 Chen | REV. AO | UNIT mm | SHEET 1/1 |
| PART NUMBER 威納料號 Refer to ordering info | CUSTOMER P/N 客戶料號 - | DATE 日期 Aug.27,09' | GENERAL TOLERANCE 一般公差 | | | |
| DWG NO. 圖號 WP009-1409194-B | FILENAME 路徑 WP/009 | SCALE 比例 N/A | <p>MM X.X = ±0.38 X.XX = ±0.25 X.XXX = ±0.05 UNLESS OTHERWISE SPECIFIED</p> | | | |

A4

CUSTOMER DRAWING