

ENG.NO. W0028-1506061

Rev 版次	Revision note 變更內容	Date 日期	DR 制圖
A0	Original Release	Aug.27,13'	Chenyq

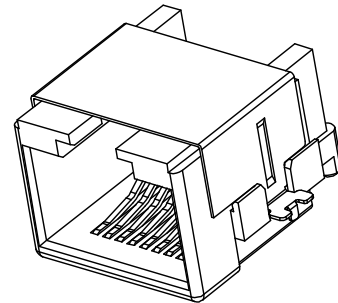
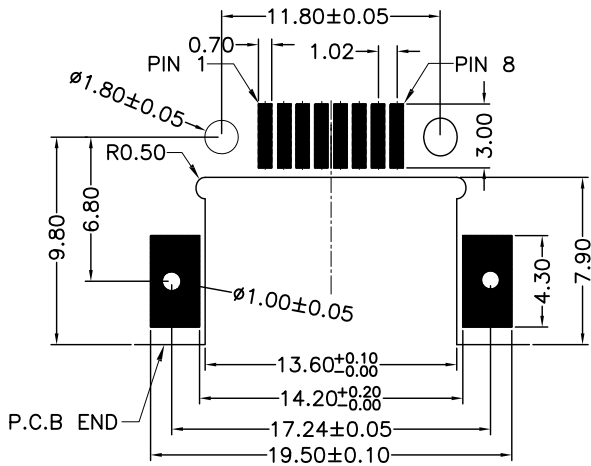
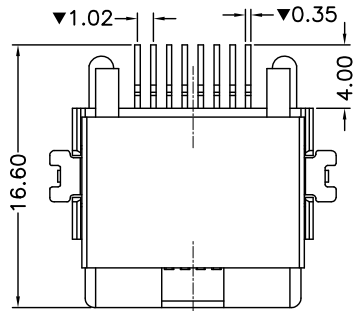

Recommended P.C.B layout(T=1.20mm)

PCB TOLERANCE:±0.05

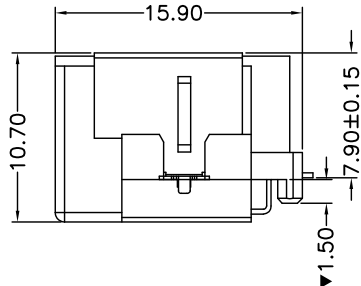
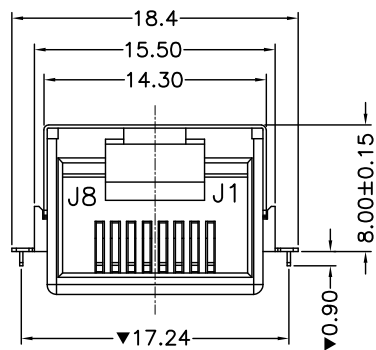

MECHANICAL:

1. Withdrawal Force: 8Kgf Min.

ELECTRICAL SPECIFICATION:

- Rated Voltage And Current: DC 100v Max, 500mA Per Contact.
- Insulation Resistance: 100 MΩ. Min.
- Contact Resistance: 45mΩ Max.
- Dielectric Withstanding Voltage: 500V/AC.
- Operating Temperature: -30°C~+85°C.
- 6."▼" Is Important Control Size.

Ordering information:

3250K- 8 X 000 X B

PLATING CODE
 2 : GOLD FLASH PLATED
 3~9 : 3~9u" MIN. GOLD PLATED
 A : 10u" MIN. GOLD PLATED
 B : 15u" MIN. GOLD PLATED
 C : 30u" MIN. GOLD PLATED
 D : 50u" MIN. GOLD PLATED

INSULATOR COLOR
 K:BLACK(STANDARD)
 Y:YELLOW
 G:GREEN
 W:WHITIE

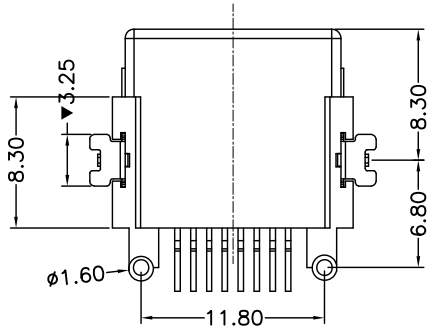

RoHS COMPLIANT

③	Terminal:Phosphor Bronze,Gold Plated	8
②	Shield:Brass Tin Plated	1
①	Housing:LCP,G/F,UL94V-0,Color:See Part No.	1
ITEM	DESC	Q'TY

威納電子 WINPOINT ELECTRONIC CORP. www.winpoint.com.tw		Title 名稱 RJ45沉板式SMT TYPE				
DR:制圖 Chenyq	CHK'D 審核 Kenny_shi	APP'D 核准 Chen	REV. AO	UNIT mm	SHEET 1/1	
PART NUMBER 威納料號 Refer to ordering info -		CUSTOMER P/N 客戶料號 -		DATE 日期 Aug.27,13'		
DWG NO. 圖號 WP009-1506365-B		FILENAME 路徑 WP/009		SCALE 比例 N/A		
GENERAL TOLERANCE 一般公差 MM X.X = ±0.38 X.XX = ±0.25 X.XXX = ±0.05 UNLESS OTHERWISE SPECIFIED			ANGULAR ±3°			